

AN EXPLORATORY ANALYSIS OF THE IMPACT OF CHINESE CULTURE IN SIX SIGMA IMPLEMENTATION IN HONG KONG

Ng, Chi Kuen Ivan
Capstone Enterprises Ltd., Hong Kong
ivanng@capstone.com.hk

Chin, Kwai Sang
City University of Hong Kong, Hong Kong
Wuhan University of Technology, China
mekschin@cityu.edu.hk

Abstract:

Research on the relationship between Chinese culture and Six Sigma implementation in Greater China is limited. Employing quantitative method by survey and utilizing a shortened version of the Chinese Value Survey (CVS; Bond et al., 1987), this study examines the relationship between three selected dimensions of Chinese value characteristics and Six Sigma implementation. In addition, this exploratory analysis assesses three factors: objectives, activities and actions. This is to investigate what strategic factors must be emphasized of Six Sigma implementation. Considering that Chinese cultural elements are part of the culture present in organizations and that these elements can affect Six Sigma implementation, this study measures Chinese culture in both manufacturing and non-manufacturing industries in Hong Kong. Six Sigma has been one of the most popular management methodologies employed in the West in the last three decades. This specific tool of quality management has been adopted in China, mainly through Hong Kong which has been the gateway of Sino-global business. The tendency of Six Sigma in companies and industries today is that some complete Six Sigma projects as planned, some continue with Six Sigma, and some abandon it. In recent years, rates of abandonment and increasing cases of workplace resistance have drawn the attention of Six Sigma academics, consultants and companies. The study result shows firstly that Chinese cultural values do not aid or obstruct Six Sigma in terms of the three dimensions chosen for the test: Integration factors, Confucian work dynamics factors, and personal factors. Moreover, two (underlined) of the three guanxi variables (reciprocation of greetings, favors, and gifts; protecting your "face"; and respect of tradition) in the Confucian dimension do not have significant impact on the organization's running of Six Sigma. Secondly, as to strategic factors, only setting objectives is indispensable for organizational change by Six Sigma.

Keywords: Six Sigma, Culture, Chinese Culture, and Quality Management

1. INTRODUCTION

Implementing Six Sigma is a change process by management decision for a planned change in preparation for and application of Six Sigma aiming at the designed outcomes. This study explores to measure “soft” factors of culture that may affect the implementation process by utilizing a research model: The Chinese Value Survey (CVS; Bond et al., 1987). As there is no relevant model to test the three strategic factors of organizational change by Six Sigma: objectives, activities and actions, an EFA is employed to identify latent constructs for further statistical analysis.

The Six Sigma methodology has a development history of over two decades in Greater China. The current Chinese experience is: It becomes prevalent that, explicitly or inexplicitly, Six Sigma is either resisted or modified by the workforce in Chinese culture of operation. This study looks at the problem in Hong Kong, where Six Sigma has some 30 years of experience, and is the strategic gateway for Western investment in China and for Sino-global business and trade.

1.1. Research Problem

This study looks into the problem that cultural factors can impact Six Sigma implementation.

After three decades of practical application and industrial experience, Six Sigma is treated as one of the few popular management drivers in the business world, and has been co-existed with other methodologies rather than treated as the selected, sole, company-wide, strategic initiative as instituted by Motorola. Apparently, the original Six Sigma designed in the mid-1980s looks not as useful or popular today.

As far as culture is concerned, when Six Sigma runs counter to existing culture, value system and mind set in the workplace, cultural incongruity may impede its application, and may eventually cause ultimate failure of Six Sigma projects.

If Six Sigma can be a successful management initiative simply by rolling out the structured, disciplined, engineering tools without consider other factors, is a question that also comes under increasing attention. Investigating into the cultural factors that can influence Six Sigma implementation outside its mechanical procedures and processing is the central theme of this study.

1.2. Challenge of this Research

The challenge is that this study tries to look at the “soft” factors of cultural issues in reality of a business initiative which is essentially based on and work for project success in terms of “hard” factors. Dealing with the research topic from both exploratory and confirmatory perspective, this study attempts to provide a solution to the business decision makers and Six Sigma professionals.

This study investigates that how a successful methodology in the West can produce the designed outcomes in the Chinese environment, and what Six Sigma can do to yield the planned and designed outcomes in Hong Kong, and probably in the Chinese way of operation. This study also explores into the strategic factors that are imperative to the success of Six Sigma.

The present researcher is active in running Six Sigma projects in both the manufacturing and servicing industries. There is still growing demand for Six Sigma in the market. This study thus helps quality professional to understand the practicability of Six Sigma. On the academic side, it can induce further study on quality management by Six Sigma and can contribute to knowledge.

2. LITERATURE REVIEW

The research community has a rich depository of literature which gives insight into Six Sigma application and implementation. These studies provide information for an appropriate understanding of the relationship between Six Sigma and its success, and cultural factors.

As this study takes cultural factors as essential study variables, sub-sections here encompass culture theories and studies, national cultures, and Chinese cultural characteristics and guanxi issues.

2.1. Six Sigma Overviews

Prior researches (e.g., Coronado & Antony, 2002) recognized the importance of cultural elements in the introduction of a new management strategy. Thomson (2003) pointed out that it was necessary for decision makers to handle the compatibility between Six Sigma assumptions and the current culture of an organization when considering a cross functional Six Sigma project. Chan (2006) studied the implementation of Six Sigma in companies in Hong Kong and in the Pearl River Delta regions of Southern China. He designed the readiness assessment model (RAM) to evaluate the organizational and cultural factors, and measured the readiness of the case companies before implementing Six Sigma.

There are therefore rooms for this exploratory study about the relationship between cultural elements, particularly Chinese culture and quality management by Six Sigma.

2.2. Six Sigma Implementation

Literature provides a number of study directions and aspects of Six Sigma implementation. Huo (2006) raised the importance of TQM experience and other quality initiatives before implementing a Six Sigma planned change. The basic organizational and operational hurdles are in the start-up stages (Gijo & Rao, 2005), preparation of cultural and organizational aspects as well as adequate knowledge sharing capacity (Pettigrew, 1998, Sadagopan et al., 2005; Rajamanoharan & Collier, 2006; Lee et al., 2011).

There is a relationship between organizational capability and requirements for implementation. Goetsch and Davis (2013) listed four requirements of TQM: (1) commitment by top management, (2) commitment of resources, (3) organization-wide steering committee, and finally planning and publicizing. However, Antony and Banuelas (2002) were able to identify a further eleven key ingredients for effective implementation of Six Sigma: (1) management commitment and involvement; (2) a thorough understanding of Six Sigma methodology, tools and techniques; (3) linking Six Sigma to business strategy; (4) linking Six Sigma to customers; (5) project selection, reviews and tracking; (6) organizational infrastructure; (7) cultural change; (8) project management skills; (9) linking Six Sigma to suppliers; (10) training, and finally, linking Six Sigma to employees (human resources).

These requirements and stipulations are reflected in various Six Sigma textbooks (e.g., Breyfogle III, 2003; Kubiak & Benbow, 2009; Pyzdek & Keller, 2010), and are confirmed in research and practitioner articles (e.g., Byrne, 2003; McAdam & Evans, 2004; Zu & Fredendall, 2009; Moosa & Sajid, 2010). These factors are present in both application and implementation, but vary in different organizations.

There also exists a close relationship between Six Sigma implementation and organizational culture, and during the last decade, researchers began to link Six Sigma implementation with organizational culture (Szeto & Tsang, 2005), and mapped Six Sigma practices with organizational culture (Zu et al., 2010). Zu et al. (2008) identified Six Sigma role structure, Six Sigma structured improvement procedure, and Six Sigma focus on metrics, as three new practices for implementing Six Sigma's concept and method.

It is also helpful to look at case studies for understanding Six Sigma implementation and practice. The multilevel case study by McAdam and Lafferty (2004) concentrated on measures and results of Six Sigma in statistical control and strategic change respectively. It embraced process and people, and highlighted the evaluation process for the current culture of organization. Another case study (Nonthaleerak & Hendry, 2008) emphasized on a couple of areas of weakness within Six Sigma implementation i.e., the mental fear of statistical and quality tools, and the crucial factor of the presence of Six Sigma professionals. These two case studies show a clearer picture of implementation and provide more practical advice to practitioners.

Cheng (2008) conducted a study on Six Sigma in Taiwan where the methodology was developed in this major manufacturing territory in Greater China. It was an empirical case study on merging Six Sigma implementation with TQM improvement tools. The result was that it helped competitive advantage, and suggested "to incorporate a strategic element into the process" (2008: 194). Yang et al. (2008) reported another aspect of Six Sigma experience in Taiwan, and identified that new adopters used a modified model instead of adhering to the existing and trialed GE model. Raisinghani (2005: 491) held that the

Six Sigma methodology is “best used in conjunction with other more comprehensive quality standards”. The studies of Cheng and Yang with their associates witnessed a trend of regional experience of Six Sigma implementation, which is close to the situations both in Hong Kong and in mainland China. Raisinghani suggested a phenomenal change of the role of Six Sigma in the commercial world.

As Six Sigma develops within Chinese enterprises, issues of Six Sigma implementation are observed. Lee et al. (2011) identified six problems of implementing Six Sigma in China, namely: (1) low education and lack of intellectual capacity; (2) high staff turnover rate; (3) financial limitation; (4) lack of time resource; (5) lack of strategic vision/long-term goal formulation, and finally, (6) resistance to change. These issues can be compared to the factors concerning the abandonment of Six Sigma by some companies in the discussion chapter.

In the survey study, Lee et al. (2011: 188) attempted to develop a framework of the “readiness self-assessment model” (RSM) to evaluate “the readiness of an organization towards Six Sigma implementation” for Chinese enterprises. Chan (2006) made a similar, but less comprehensive attempt for manufacturing companies in Hong Kong and Southern China, to develop the Readiness Assessment Model (RAM), as well as the Six Sigma Performance Model (SSPM). Chan’s RAM considers “organizational and cultural readiness”, and “methodology and tools readiness” factors. These two survey studies set an example and provide item-question ideas for the present study.

2.3. Culture and Cultural Models

The word culture had long been used to refer to cultivation of mind. Come under the discipline of anthropology, culture had been increasingly examined in the second half of the 20th century. A succinct definition is offered by Mead (1953; Martinsons & Davison quoted, 2003:3): “Shared patterns of behavior”.

The context cultures of Hall (1989) which explain cultural tendency of behavior and communication in terms of low and high context systems. Chinese is a complex and multi-institutional type of culture, and is on the high-context end. In industrial and commercial context, culture is considered within a group or about individual behavior in the workplace. Chinese is collectivistic, “focused on social interests, collective action” and “group goals and group-based performance incentives.” (Earley, 1989: 569)

In the last three decades and more, researchers suggested their own sets of cultural dimensions and orientations of study. They include the more systematic studies of Hofstede, the Trompenaars and Hamden-Turner model, and the more recent GLOBE project by House.

The first large scale, transnational, organizational and people management study is the model survey by Geert Hofstede (1980 and revised in 1986). This model postulates five dimensions of culture (power distance, individualism vs. collectivism, masculinity vs. femininity, uncertainty avoidance, and long-term vs. short-term orientation) which provides basic information for this study. Another model is from Fons Trompenaar who identifies four types of organizational culture: family, Eiffel Tower, guided missile and incubator. Trompenaars also discussed the role of authority in society and family, and identified the “achieved” status of “doing”, and the “ascribed” status of “being” (cf. Huijser, 2006). The more recent model is the Project GLOBE of House et al. (2001) which in measure extends Hofstede’s five dimensions to six (two collectivisms) dimensions, and added another three dimensions (gender egalitarianism, assertiveness, and future orientation). Covers wider areas of cultural attributes, Project GLOBE is “a multi-phase, multi-method project”.

The above explains culture, analyzes and classifies cultural elements in the data to be collected from survey study and reported on Six Sigma implementation.

Culture in national context is the focus of this study, looking at Chinese culture and its cultural implications. As Chinese culture is the context, the present research employs the Chinese Value Survey (Bond, et al., 1987), which was developed in response to Hofstede’s cultural studies to measure culture. It helps understand, analyze and classify the data collected from the quantitative survey. The survey in this study on Six Sigma academics, experts and practitioners will report results and will suggest future study directions.

2.4. Soft Factors of Culture

The study of soft factors of culture can be found in other research works. Nahm et al. (2004) tried to examine “soft issues” of organizational culture by employing Schein’s framework (1986). The model was used to assess how organizational culture (focused on espoused values and beliefs) had impact on time-based manufacturing practices and performance. The result showed positive relationships between the two sides, and organizational culture played a positive role in improving performance.

Gregory et al. (2009) made another attempt on the relationship of “soft” factors of culture and effectiveness by examining employee attitudes. It was observed that culture influenced employee attitudes, and in turn influenced outcomes. Giving a great deal of consideration to “soft” skills for the Six Sigma process change, Pinedo-Cuenca et al. (2012: 294) identified “organizational culture which encourages communication and collaboration” as one of the five success factors for SMEs’ introduction of Six Sigma.

Zu et al. (2010) performed a survey on fourteen factors, and nine of them are soft factors. Lewis et al. (2006) explore the “soft” and “hard” factors on TQM implementation. This exploratory study of two groups of 13 “soft” and 12 “hard” factors demonstrates that “the top ten critical factors are composed of seven soft factors and three hard factors”, though “soft factors are generally difficult to be measured and assessed” (p.545). Fotopoulos and Psomas (2009) also studied “soft” and “hard” TQM elements. Its findings show that performance is mainly influenced by “soft” elements.

These previous studies prepare grounds for the present researcher to explore into the impact of cultural factors in Six Sigma implementation.

2.5. Business Studies and Culture

Leading this section is the relationship of business studies with cultural issues. It embraces business studies, organizational culture and national culture. The subject-themes covered are core values and characters of this present study.

Until the mid-1980s, most business and management studies emphasized economic factors on the “effective transfer of technology”, but gave little effort towards identifying “the constraining influences of the cultural factors” (Kedia & Bhagat, 1988: 559). The recognition of cultural factors in business management remained implicit. Kedia and Bhagat suggested to consider explicitly “the interactions among technology and cultural variations” and “absorptive capacity and related organizational context-based variables”, and to “place greater emphasis on interdisciplinary frameworks” (1988: 568, 569). In this period of time, the Hofstede four-dimension model developed in the early 1980s was the major tool for measuring culture.

In mid-1990s, international business had a rapid growth pattern in Asia, particularly in the western regions of the Pacific Rim. Western multinational corporations (MNCs) were establishing more and more manufacturing arms in the emerging economies in Asia. Cultural issues and managing diversities began to catch the attention of both academics and practitioners. Researchers recognized the reality of cultural “individualism” and “fundamental national differences” (Franke et al., 1991). Organizational culture exists in business lines or divisions of MNCs. It is “common practices” that “can bridge national differences in values among organizational members” (Hofstede, 1994b: 12)

In addition to his model of four cultural dimensions, Hofstede (1986 and 1994a) began a significant collaborative research named as the Chinese Value Survey with Bond et al., (1987), and identified a fifth cultural dimension. This was initially called “Confucian Dynamism”, which not only can apply to Chinese and East Asian countries, but is also relevant on a global scale, to different countries and cultures. It was renamed long-term versus short-term orientation (or “time orientation” by Martinsons et al., 2009), which refers to a dynamic of “values oriented towards the future” (Hofstede, 1994a:10). This fifth dimension was developed from the Chinese Value Survey (CVS) questionnaire worked out with Bond (cf. Hofstede & Bond, 1984). Primarily applied to Chinese or Confucian culture, the CVS model is designed to measure culture in both Eastern and Western countries, and is a direction of “cultural relativity” which “depends on the environment”, contexts or histories (cf. Hofstede, 1993), and “offers

great possibilities for synergy and for learning” in a world demanding “intercultural cooperation” (1994a: 12).

Hofstede (1994b) restated the “five dimensions of national culture” (power distance, individualism versus collectivism, masculinity versus femininity, uncertainty avoidance, and long-term versus short-term orientation) that were coined over years of study. Hofstede also explained the difference of national cultures and organizational cultures.

In the world of commerce, globalization came onto national and commercial agendas in the early years of the 21st century. Economic activities and multinational business were mushrooming in the promotion of globalization. However, convergent and divergent forces of culture coexist in business operations, and in the formation of the global economy.

The efforts of Leung et al. (2005) had the following noteworthy points on culture and international business (IB), which are relevant to this present study. Initially Leung et al. observed “issues surrounding cultural convergence and divergence, and the processes underlying cultural changes” (2005: 357), and found that “while convergence in some domains of IB activity is easily noticeable. ...significant divergence of cultures persists” (2005: 361). This gives light to cultural diversity in international business. Second, their study provides a general picture of levels of culture which describes from a dynamic view, a multi-level model of culture, from global, national, organizational, group to individual. Third, their study concluded that cultural issues are still a “growth” area. Globalization “creates a new collective and impersonal entity that affects people’s identity” (2005: 364).

International business gave rise to the BRIC(S) countries – Brazil, Russia, India, and China in 2009 (and included South Africa in 2010). With Asia in view, China and India were the fastest growing economies in the world in the first decade of the 21st century. In 2011, China overtook Japan to become the world’s second biggest economy. However, contributing to academic management studies in Asia, Bruton and Lau made efforts in micro organizational behavior/human resource studies, macro strategy studies, and multi-level studies including organizational culture and strategic organizational change. Bruton and Lau commented, considering the research community today, that “management research remains principally focused on mature markets in North American and Europe” (2008: 636), and that the diverse context in the regions of Asia allows “researchers to extend and revise theories through the consideration of new contextual variables” (2008: 636), and can “develop new theories, that will help to shift the management research paradigm” (2008: 650). Their review is indicative to this present study, as it employs theory and models of study to explore and measure factors and variables of the research problem.

With globalization in view, quality management initiatives became popular in China in the early years of the 21st century. Six Sigma is a key management initiative which requires core assumptions and quality practices (cf. conclusion of Kull & Wacker, 2010: 236). However, all such methodologies require significant results in terms of flexibility, efficiency and effectiveness in operations management. A smooth execution and operation of these pre-requisites can encourage effective implementation of these initiatives. Martinsons et al. (2009: 123) advised that, instead of “a one-size-fit-all approach”, MNCs “should plan and implement change flexibly”, and “must exercise cultural sensitivity and globalize their best practice”. These recent studies give more hints to investigation on the impact of cultural factors on Six Sigma implementation.

2.6. National Culture

The national aspect of culture refers to cultural elements within a nation (Minkov, 2013) that identify with certain characteristics of an individual, a group, an organization, and associated social levels.

Researchers generally employ Hofstede’s five dimensions, and few utilize Trompannars’ five orientations. Developed partly from Hofstede’s cultural components to nine core dimensions, the more recent Project GLOBE by House et al. (2001) is reviewed and applied by researchers more regularly in recent years (e.g., Leung et al., 2005; Minkov, 2013).

Another point of study is the existence of subcultures in a populace, heterogeneous country. Dibella (1996) found that culture could be a detrimentally negative factor to planned organizational change.

This is particularly true “in multiple cultural systems concurrently at the sub-cultural, organizational, and societal levels” (1996: 368). Regarding sub-cultural elements, from another angle, Huo and Randall (1991: 160) took a decompositional approach for “investigating subcultures within national boundaries”, assuming that China is culturally heterogeneous (cf. Huo and Glinow, 1995), instead of a compositional approach which assumes an overall national culture.

Whether Six Sigma is culture bound, and what aspects of culture affect implementation of this methodology have been long-asked questions. Pisani et al. (2009: 1135) advised, “There is a clear need for research to assess the impact of national culture on the stages of the Six Sigma methodology. National culture has the potential to affect the way in which Six Sigma is implemented in internal consulting efforts and its overall effectiveness.” This present study will examine the impact of Chinese national cultures on Six Sigma implementation. Survey results will report findings in Hong Kong.

2.7. Chinese Culture of Guanxi

The concepts of guanxi take roots from Chinese feudalistic family traditions (Dunning & Kim, 2007; Rarick, 2009; cf. Mao et al., 2012), and Confucianism which “emphasizes authority, order, harmony, loyalty and personal relationships. It assumes that people exist in a web of harmonious and orderly relationships”. (Zhang & Zhang, 2006: 378) The secondary meaning of guanxi is that of an interpersonal relationship. Organizational network relies on the individual guanxi established (Tsang, 1998). A Chinese “turns to his or her guanxiwang, or ‘relationship network’, for help” (Hutchings & Murray, 2002: 185) when encountering personal or organizational problems. This relationship can tap deep to form network which brings out the issues of “face”, trust, reciprocal obligation, and exchange of favors. The guanxi network can build up for family members and relatives, for friends, neighbors, colleagues and classmates, and even among strangers.

Research identifies that individual guanxi has influence on organizational performance and affects organizational dynamics (e.g., Luo & Chen, 1997; Zhang & Zhang, 2006). However, Tsang (1998) found that guanxi for competitive advantage had little theoretical basis. Zhang and Zhang (2006) investigated work group emotion and Chinese guanxi culture, and found that “group emotion is deeply affected by national culture” (2005: 81). Huang et al. (2008) concluded that the cultural factors of face and guanxi affected knowledge sharing in organization.

This review of guanxi has two main significances. First, the social exchange aspects of guanxi that build into a work culture which is the element of mutual trust in the workplace can help understand the effectiveness of organizational development by Six Sigma as a means of intervention. Second, the issue of guanxi can help explain the employees’ mind set, attitudes and behavior towards work processes and new business systems. For this reason, the questionnaire survey will explore the variables Chinese Value Survey and its influence to Six Sigma implementation, and is useful for understanding the influence of Chinese culture to this Western introduced methodology.

Researchers have different views on the impact of national cultural factors on organizational change. There are also sub-cultural elements in a multi-racial and heterogeneous country like China or India. For example, Huo and Randall (1991) assessed subcultural differences in China (cf. Kwon 2012); Redfern and Crawford (2010) examined regional business ethics in China. Apart, researchers (e.g., Luo & Chen, 1997; Zhang & Zhang, 2006; Lin & Ho, 2010) found that, in Chinese culture, guanxi variables are also causal relationships that have impact on business operation in China.

2.8. Chinese Value Survey (CVS)

In his book *Culture’s Consequences* (2001), Hofstede recollected that the CVS was conceived (Hofstede & Bond, 1984) and constructed (Bond et al., 1987) for analyzing primarily Chinese and Eastern values.

The CVS is divided into four factors of altogether 40 value-items as integration, Confucian work dynamism, human-heartedness, and moral discipline. Except uncertainty avoidance, the Hofstede model and CVS were largely similar and common. These cultural dimensions are universal human traits. CVS can be acted as a “cultural synergy” to complement national culture dimensions in management studies.

Viewing that national cultural elements are part of the culture present in organization, and that these elements can impact organizational change, this research employs a shortened version of Chinese Value Survey (CVS) to test and examine relevant culture values. The survey result provides findings on how Chinese culture influences the implementation process of Six Sigma. Reviewed and advised by quality management academics and experts, a total of 18 out of 40 value-items are selected for the survey. Six items each from three dimensions: integration, Confucian work dynamism, and personal factors. These three dimensions are selected and modified from the measure guide of Fields (2002:273). They all are essential to basic Chinese cultural and guanxi traits, and employee's workplace attitude and behavior.

The CVS can also be employed in surveys for different purposes and levels of survey population. (e.g., Matthews, 2000) This present study employs the selected 3 dimensions of 18 CVS item-variable to examine the influence of Chinese values to Six Sigma implementation.

Here is this shortened version of CVS (Bond et al., 1987):

- Integration Factors
 1. 隨和 Harmony with others
 2. 團結 Solidarity with others
 3. 不重競爭 Non-competitiveness
 4. 信用 Trustworthiness
 5. 保守 Being conservative
 6. 貞潔 Chastity in women
- Confucian Work Dynamism Factors
 7. 儉 Thrift
 8. 耐力 (毅力) Persistence (Perseverance)
 9. 禮尚往來 Reciprocation of greetings, favors, and gifts
 10. 穩重 Personal steadiness and stability
 11. 要面子 Protecting your "face"
 12. 尊敬傳統 Respect for tradition
- Personal Factors
 13. 勤勞 Industry (Working hard)
 14. 謙虛 Humbleness
 15. 忠於上司 Loyalty to superiors
 16. 學識 (教育) Knowledge (Education)
 17. 廉潔 Resistance to corruption
 18. 文化優越感 A sense of cultural superiority

2.9. Summary

Given that this work is focused on Six Sigma implementation, the larger part of this study is engaged in the literature of three subject matters: Six Sigma, culture and quality management. The literature reviewed encompasses the scope of the three research questions, and is helpful in identifying factors of Six Sigma implementation and the more abstractive relationship of congruence between Six Sigma and cultural factors.

3. RESEARCH FRAMEWORK AND METHODOLOGY

The framework map below provides the layout of research, which examines the impact of Chinese cultural factor on Six Sigma implementation, and analyzes the respective variables concerned.

Picture 1: Concept map – organizational development by six sigma

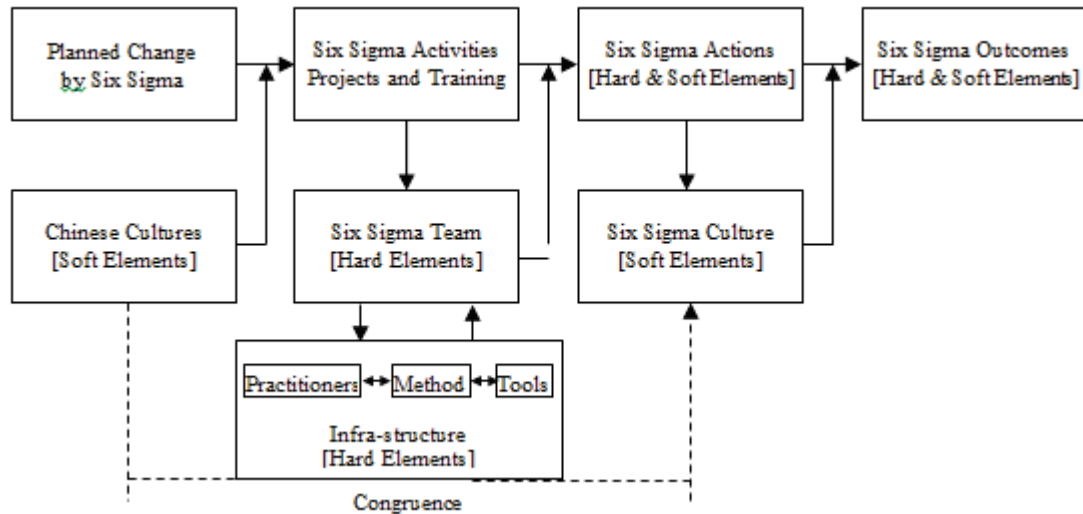

The top two rows of this map show the major variables in this study. The third row illustrates a value-item box which extends from the moderator variable of the Six Sigma team. It is an infrastructure of three elements established and used for Six Sigma implementation.

The elements of Six Sigma implementation are framed into the change process. The corresponding variables are as follows: planned change through the application of Six Sigma, change activities of Six Sigma, change actions of Six Sigma, and finally the change outcome of Six Sigma. The upper row of this map shows the aggregated, causal relationship of four change variables in the process chain in terms of Six Sigma.

The middle row notes both soft and hard factors of Six Sigma which moderate between these variables of the change process. The first and third moderator variables are soft factors of culture. In the change process, the Chinese cultures are to cause either positive or negative change, and converge or diverge with the new Six Sigma culture in the course of Six Sigma implementation. It is a central point of this research. The survey result will reveal how and what cultural factors affect consistency of implementation, and confirm hypothesis.

The middle moderator in the lower row represents the Six Sigma infrastructure, which is extended from hard elements of the Six Sigma team. The three components are core, hard, building elements of Six Sigma in organization.

3.1. Research Questions

The following two research questions are to be considered:

1. What strategic factor must the management emphasize for Six Sigma implementation?
2. How does Chinese culture impact Six Sigma implementation?

These two questions cover the research subjects, and are designed to deal with the research problem, and to produce the research results.

3.2. Hypothesis

Two groups of hypotheses on the research topic are proposed.

This study examines variables that may affect process compliance and its final yield of outcomes. Cross-functional strategic change affects overall processes, current (Chinese) culture, and as a result, satisfies voices of present and potential customers. This research analyzes effectiveness and usefulness of the Six Sigma methodology. This study considers Chinese culture as the main

independent variable in the cross functional change process. The dependent variable of outcomes is the result of continuous, statistical process control and performance of Six Sigma projects.

Three variables of the change process are examined. First, the variable of policy and objective can be viewed as the forefront matters of the planned change. Second, the mediator variable of change activities comprises of projects, and training that enable employees to gain knowledge and experience of Six Sigma. This helps build a cross-functional Six Sigma team, Six Sigma infrastructure of practitioners, method and tools. They are solid ground for long term results and success. The third mediator variable of change actions refers to business, operation and employee levels of operation which in turn motivate and implement beneficial changes in different departments. Managers focus on cooperation, and enforce plans in the workplace which enable greater learning which will result in improved performance. It is an evolutionary and transformational process. As for exploration, three hypotheses of Six Sigma objectives, activities and actions are proposed:

- 1a. Six Sigma implementation is positively related to Six Sigma objectives set for organizational development.
- 1b. Six Sigma implementation is positively related to Six Sigma planned activities set for organizational development.
- 1c. Six Sigma implementation is positively related to Six Sigma actions set for organizational development

Given that this study is focused on the successful implementation of Six Sigma, a significant part is engaged in three specific subjects: Six Sigma objectives, Six Sigma implementation, and Chinese culture. These subjects develop and formulate the two research questions in this study, and are vital for understanding the relationship between Six Sigma implementation and Chinese culture.

This research examines Chinese cultural elements and their roles in organizational change by Six Sigma, and to probe into the ways that Chinese culture may positively affect Six Sigma implementation, and the Chinese culture elements that can influence the introduction of Six Sigma to an organization as a business initiative.

To achieve some or all of the objectives of a Six Sigma project, the project manager has to cooperate closely with all functional departments in order to set up new Six Sigma training and courses. A reward system is then introduced in consideration of employee development which prepares them to become Six Sigma professionals. Employees learn Six Sigma for engaging themselves in the change plan and process of Six Sigma and organizational change. These programs provide new knowledge and qualifications to employees.

Six Sigma is designed for strategic and long term change. In a cross-functional Six Sigma project, cost saving, process improvement and efficiency, performance excellence and accuracy, and customer satisfaction are among those management objectives. Being an instrument for organizational change, Six Sigma is to be implemented in terms of months, which will enable the Six Sigma culture to present and take root, and the expected performance can continue on an ongoing, long term basis.

As far as performance excellence and continuous implementation is concerned, there will be management issues about workplace culture and workforce behavior. This part of study investigates the established characteristics of Chinese culture, the impact of these characteristics to the presence of Six Sigma in the organization, and the continuous process improvement control after rolling out the project programs. The success and result of a Six Sigma project depends on dynamic and consistent application and stable inter-departmental compliance for process control after implementation.

This confirmatory part of study employs 3 dimensions of 18 selected and suitable Chinese Value Survey (CVS) which is a shortened version of CVS (Bond et al., 1987). The 3 dimensions are Integration Factors, Confucian Work Dynamism Factors, and Personal Factors (see Section 2.8).

The 3 hypotheses on the influence of Chinese values to Six Sigma implementation are:

- 2a. Six Sigma implementation is positively affected by the Chinese culture of Integration Factors.
- 2b. Six Sigma implementation is positively affected by the Chinese culture of Confucian Work Dynamism Factors.
- 2c. Six Sigma implementation is positively affected by the Chinese culture of Personal Factors.

3.3. Research Method

This research takes a positivist approach, and employs a quantitative method of study. Comprising a two-wave survey, this method of study is considered suitable for it can collect a more consistent respondent information and data for analysis of the validity and reliability of the research variables.

The Chinese Value Survey (Bond et al., 1987; cf. Hofstede & Bond, 1984), an extension of Hofstede's study, is more appropriate for studying employee behavior and attitude in the context of Hong Kong. It also suits this exploratory study of Six Sigma implementation.

Guided by the two research questions, the survey derives components from the variables in the concept map. The survey questions are designed to explore into construct variables and confirm the study model. It was a population survey, and the participants were members of Six Sigma and quality societies and quality management individuals. Each question is measured on 7-point Likert scale. The Cronbach's alpha is used to assess reliability.

4. RESEARCH RESULTS

The survey data collected was from a two-wave questionnaire which was sent to the participants in a time frame of some two weeks. They were checked through. Missed data was confirmed from the respondents either by phone or email.

4.1. Survey by Questionnaire

The two-wave survey was run online. The population size was counted 1,713. Raw result showed that Wave 1 had 328 responses, which was 19.1% of the population, and Wave 2 had 162, which was 9.5%. The edited feedback of Part 1 was 144 responses, and Part 2 was 116 responses. Thus, there were 116 sets of completed Wave 1 and Wave 2 responses of the survey (N=116). This was 6.8% of the population.

The survey shows that, 50% (58) of respondent finished Wave 1 within 10 minutes, 23% (27) finished it between 10 to 20 minutes, and 27% (31) took more than 20 minutes to finish it. For Wave 2, 61% (71) finished it within 10 minutes, 23% (26) finished it between 10 to 20 minutes, and 16% (19) took more than 20 minutes to finish it. 50% of the respondents finished Wave 1 in 10 minutes, and 61% completed Part 2 in the same time frame.

The questionnaire generally fulfilled the set time factor, and the other suggestions made by the academic and professional reviewers of the pilot survey, and demonstrates itself a reliable element of the survey.

4.2. Factor Analysis

The first step is an EFA for the three Six Sigma independent variables: objectives, activities and actions. The next step is to observe and measure both dependent and independent variables by assessing their correlations. The third step is a logistic regression to further test significance of the independent variables, and to predict outcome for the companies implementing Six Sigma.

Exploratory Factor Analysis (EFA)

There is no existing model for examining the three Six Sigma independent variables under study. First of all, irrelevant variables were deleted. An EFA was employed to identify latent constructs by testing relevant variables. It was for creating scales, and another one was for confirming models for the variables before they could be used for further factor analysis and finally for hypothesis testing.

This EFA is a test of the variables of the three latent constructs of the Six Sigma. The objectives construct has 9 items, the activities construct 12 items, and actions construct 15 items. There are altogether 36 items. Unfitted items were deleted in the process. 5 items in each of the three constructs

were consistent for further factor loading and analysis. The 15 items, their loading and respective Cronbach's alphas are listed Table 1 below.

Table 1: EFA Study: Factor loadings of items assessing objectives, activities, and actions

	Six Sigma Objectives ($\alpha = .80$)	Six Sigma Activities ($\alpha = .91$)	Six Sigma Actions ($\alpha = .89$)
Improve business competitiveness	.79		
Build status of quality organization	.74		
Achieve enhanced quality	.74		
Increase organization's leading role in industry	.67		
Enhance organization's problem solving ability	.66		
Training to enhance employee involvement		.83	
Quality workshops for educating employees		.80	
Training Six Sigma method – DMAIC, as mindset		.77	
Rewards and recognition for performance		.65	
Activities to build Six Sigma values		.64	
Communicate effectively			.86
Establish positive attitude			.82
Employee empowerment			.76
Benchmarking			.62
Stakeholders management			.62

The factor loadings are from .62 to .86. Cronbach's alphas for the 3 constructs are: Objectives = .80, Planned Activities = .91, Actions = .89. The alphas cross the threshold of .7, and are above .8. It is therefore claimed that internal consistency for the item variables in these three constructs is fairly reliable.

In the above analysis, the three constructs: objectives, activities and actions, are satisfactory and therefore deemed valid for hypothesis testing of the research topic after factor analysis.

Confirmatory Factors Analysis (CFA)

The CFA performed in this study is to confirm scale with existing model of item-variables before they are used for further factor analysis and finally for hypothesis testing.

Table 2: Model Fit Summary for the CVS Factors

Model	CMIN/DF			GFI			CFI			RMSEA		
	1 st	2 nd	3 rd	1 st	2 nd	3 rd	1 st	2 nd	3 rd	1 st	2 nd	3 rd
Default Model	4.08	3.18	2.35	.65	.77	.86	.71	.82	.91	.15	.12	.10

Note: CMIN/DF = the minimal value of the discrepancy, C, divided by the degree of freedom; GFI = goodness of fit index; CFI = comparative fit index; RMSEA = root mean square error of approximation. (1st, 2nd and 3rd are the three runs of respective index figures)

This CFA (Table 2) was completed in order to assess the significance of Chinese culture in terms of CVS, as part of this research on the relevant soft factors of culture. Here below is the summary of confirmatory analysis, which lists the loadings for the Chinese Value Survey (CVS) variables:

For the 6-item each of the three CVS dimension, three factor loadings were run. In the first run, model fit summary showed that the covariance between factors was marginally below the threshold ($\chi^2 = 538.84$; $DF = 132$; $P = .00$). Crossed the second and reached the third run, the covariance became acceptable ($\chi^2 = 145.51$; $DF = 62$; $P = .01$). The GFI was .86, RMSEA was .10, and CFI was .91.

Picture 2: Confirmatory factor analysis of Chinese value survey (CVS)

Factors for Analysis: Integration, Confucian work dynamism, and personal

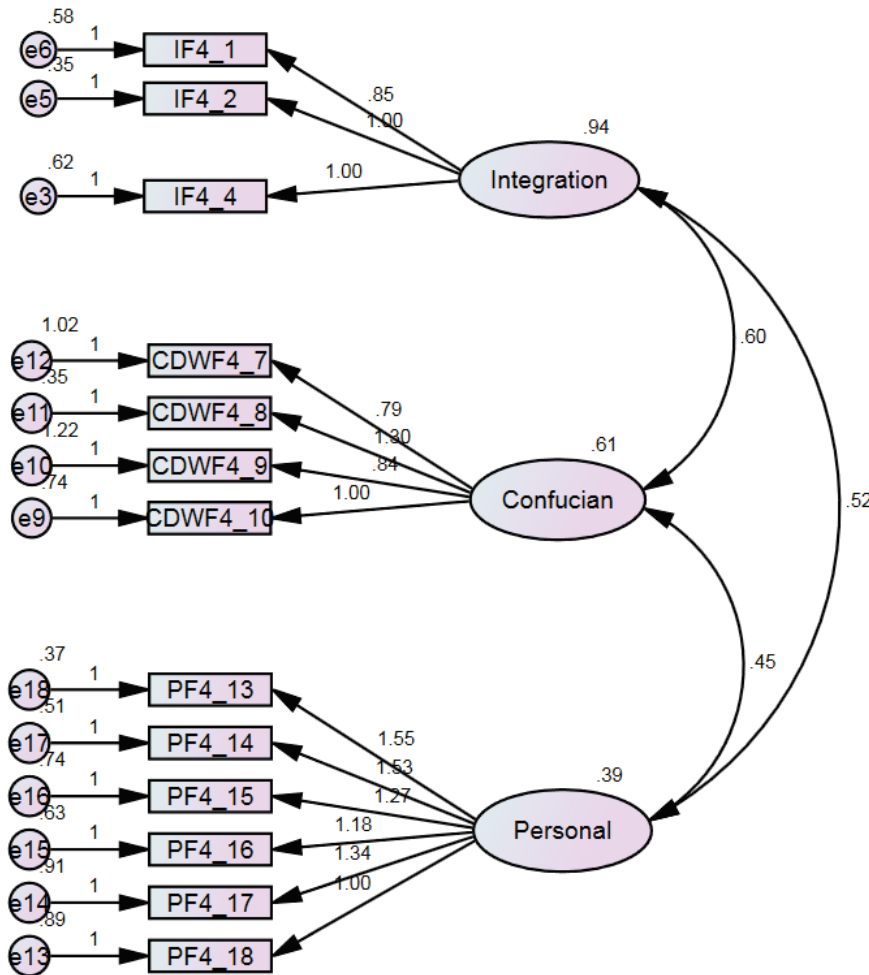

$N = 144$

Standardized coefficients shown.

All factor loadings are significant at $p = 0.001$ level (two-tailed).

χ^2 ($df = 62$): 145.512***; $CMIN/DF = 2.347$; $CFI = 0.912$; $RMSEA = 0.097$.

Cronbach's Alpha

1. Integration: .816
2. Confucian: .745
3. Personal: .859

The CFA for the three CVS constructs have reliable alpha scores.

The analysis shows that, of the 3 CVS dimension, the "integration" construct loaded 3 variables (IF1, harmony with others; IF2, solidarity with others; and IF4, trustworthiness; but deleted 3 unfitted variables (i.e. IF3, non-competitiveness; IF5, being conservative; IF6, chastity in women); the "Confucian" loaded 4 variables (i.e. CDWF7, thrift; CDWF8, persistence – perseverance; CDWF9, reciprocation of greetings, favors, and gifts; and CDWF10, personal steadiness and stability), but deleted 2 unfitted variables (CWDF 11, protecting your "face"; and CWDF 12, respect for tradition); the "personal" loaded all 6 variables (PF13, industry – working hard; PF14, humbleness, PF15, loyalty to

superiors; PF16, knowledge – education; PF17, resistance to corruption; and PF18, a sense of cultural superiority).

These categories were well-fitted and acceptable for further investigation and factor analysis.

Correlation Table

Both the EFAs and CFAs have tested the latent constructs and model variables respectively. In the EFAs, scales are created; in the CFAs, item-variables are confirmed. Thus, the next step is to investigate the correlations between study variables.

Table 3: Correlations among study variables

Variable	Mea n	St. Dev	1	2	3	4	5	6	7	8	9	10	11	12	13
1. Six Objective	Sigma 5.50	.68	.80												
2. Six Activities	Sigma 5.05	1.09	.34**	.91											
3. Six Sigma Actions	5.07	.92	.42**	.56**	.89										
4. CVS-Integration	5.199 3	.97972	.494**	.270**	.476**	.816									
5. CVS-Confucianism	4.953 8	.88013	.425**	.210*	.407**	.533**	.745								
6. CVS-Personal	5.175 7	.89578	.460**	.208*	.328**	.719**	.660**	.859							
7. Outcome Efficiency	5.13	.99	.41**	.38**	.44**	.33**	.35**	.34**	.37**	.26*	.23*	.32**	.17	.83	
8. Outcome - Quality Culture	5.03	.95	.27**	.33**	.24*	.17	.10	.16	.32**	.20	.18	.23*	.04	.57**	.86

** Correlation is significant at the 0.01 level (2-tailed).

* Correlation is significant at the 0.05 level (2-tailed).

Note: N = 92.

Cronbach's alpha coefficients on diagonal.

CVS A shortened version of version of CVS (Bond et al., 1987)

Table 3 above shows the correlation coefficients of eight variables under study. All the variables have reliable alpha scores. The lowest is the CVS dimension – Confucian ($\alpha = .75$, $p < .01$), and the highest is Six Sigma activities ($\alpha = .91$, $p < .01$).

As to the mean and standard deviation of the variables in the table, the first three are Six Sigma factors; the next three are Chinese cultural factors in terms of Chinese Value Survey (CVS). This shows that the variables have mediating effects, and could function interactively to each other. Also, this demonstrated that Six Sigma assumptions, Chinese cultural values and characteristics, and organizational culture practices could interact positively and effectively in the operation of organizational development by Six Sigma, and efficiently in the change process of Six Sigma implementation.

In the CVS variables, integration (M = 5.20, SD = .98) and personal (M = 5.18, SD = .90) factors were moderately well applied, but Confucian (M = 4.95, SD = .88) looked slightly well applied only.

The third noteworthy point is that the quality culture factor does not correlate significantly with the three CVS factors: integration ($r = .17$, ns), Confucian ($r = .10$, ns), and personal ($r = .16$, ns). This shows primarily that the all Chinese culture characteristics do not contribute to the building of Six Sigma quality culture. On the other hand, as these two sides were not correlated, Chinese culture may not cause negative influence to Six Sigma implementation and its intended or desired outcomes.

The analysis shows that all three hypotheses of group 2 are not confirmed.

Logistic Regression

Based on the first EFA study and the correlation analysis above, the logistic regression analysis was done for the three Six Sigma constructs: objectives, activities, and actions.

In the survey, three status of Six Sigma implementation were reported: The A status is completion of Six Sigma, the B status is continuation with Six Sigma, and the C status is abandonment of Six Sigma. The logistic regression (Table 4 below) was furnished to assess the companies implementing the Six Sigma methodology.

The A and B status were merged as group 1 for companies completed/continuing Six Sigma, and the C status was considered as group 2 for companies abandoned Six Sigma. Of the 116 completed sets of survey return, group 1 has 92 companies and group 2 has 24 companies.

The proposed model is "Company implementing Six Sigma". Those companies completed Six Sigma implementation, and those companies continued with Six Sigma were assigned code 1. Those other companies which abandoned Six Sigma implementation were assigned code 0. The dependent variable is thus in two types, and is thus binary. In this respect, binary logistic regression is used to predict the outcome.

Table 4: Logistic Regression Analysis of Companies Implementing Six Sigma

<u>Independent variable</u>	<u>B</u>	<u>S.E.</u>	<u>Wald</u>	<u>Sig.</u>	<u>Exp(B)</u>
Organization Type			7.41	.39	
Chinese State-owned Enterprise	.28	1.83	.02	.88	1.32
Chinese Private-owned Enterprise	2.81	1.15	.00	1.00	16.61
Foreign-owned Enterprise	2.34	1.70	1.90	.17	10.42
Hong Kong Public-listed Corporation	1.29	1.66	.60	.44	3.62
Hong Kong Private Limited Corporation	2.17	1.88	1.32	.25	8.72
Hong Kong Small- and Medium Enterprise	.61	1.61	.15	.70	1.85
Hong Kong Non-government Organization	-1.03	1.94	.28	.60	.36
Industry	-1.27	.75	2.85	.09	.28
Employee Size	.00	.00	.41	.52	1.00
Objectives	1.10	.46	5.78	.02	2.99
Activities	.40	.38	1.16	.28	1.50
Actions	-.06	.42	.02	.88	.94
Constant	-6.83	2.97	5.28	.02	.00

Model $\chi^2 = 25.61$ p. < .05

Pseudo $R^2 = .37$

N = 116

Note: There are nine variables under Organization Type. Type 9 (Hong Kong Quasi-government Organization) is used as a reference, and no respondent chose Type 7 (Hong Kong Private Unlimited Corporation) in the survey.

The analysis confirms hypothesis 1a about objectives (sig. = .02): Six Sigma implementation is positively related to Six Sigma objectives. But hypothesis 1b: Six Sigma planned activities (sig = .28) and hypothesis 1c: Six Sigma actions (sig. = .88) are not supported.

5. RESEARCH FINDINGS

The propositions were tested, and two significant findings were identified. Following is a discussion of the two significant findings.

5.1. The Importance of Change Objectives

The one finding stands out most clearly is the importance of setting clear objectives for the Six Sigma implementation. Logistic regression analysis shows that failing to create clear objectives for the Six Sigma initiative is associated with a significantly likelihood of abandoning the Six Sigma initiative. The noteworthy point here is that the content of the objective, whether pursuing quality improvements or as a means of seeking legitimacy and enhancing reputation, it does not appear to matter.

Unlike business process re-engineering (BPR) for OD and OC which drives change objectives without conforming to a formal, explicit or universal recognition, Six Sigma projects are to set objectives for definite planned activities and actions of implementation. BPR contains specific OC manipulations (Hempel & Martinsons, 2009), and TQM emphasizes baseline outcomes (Detert et al., 2000) for auditing. Nonetheless, these two and other quality initiatives do not have a certification body and system to rectify project results. The Six Sigma has developed standards to certify projects and professionals. Six Sigma is able to check real or fake projects or personnel whether the program is introduced for quality improvements, or as a means for legitimacy or reputation. However, BPR and TQM have procedures to audit results, but do not have the mechanism to perform certification.

5.2. The Role of Chinese Value Characteristics

It was predicted that Six Sigma implementations would be influenced by aspects of Chinese culture (cf. Hempel & Martinsons, 2009). However, the analysis failed to find any significant effects. While one must be cautious in discussing non-results, it is interesting that it appears that Chinese culture should not be taken as a convincing element for arguing against implementing the Six Sigma in Chinese organizations or MNCs in Southern China.

Post-survey interviews with academics and experts revealed that they found that this point was interesting and noteworthy. One commented that this was a “new and interesting” finding. This respondent elaborated that people could not simply argue that cultural issues can obstruct Six Sigma from yielding successful results in Chinese environments of operation. As the survey was carried out in Hong Kong, this interpretation of the results should be supported by further quantitative and qualitative studies.

In addition, this study also tests the effects of Chinese culture upon Six Sigma implementation. As to Chinese *guanxi*, two of the three *guanxi* variables (reciprocation of greetings, favors, and gifts; protecting your “face”; and, respect of tradition) in the Confucian dimension of CVS do not have significant influence in the organizations’ running of Six Sigma. This can represent a regional characteristic for the survey was performed in Hong Kong which is a special administration regional of China, and is a much westernized metropolitan city in the Chinese soil.

6. DISCUSSIONS

This study handles the research problem by an exploratory and empirical approach. It can be concluded that success and accomplishment of Six Sigma relies on setting clear objectives, with the breeding of a Six Sigma quality culture, and building of infrastructures and practices for Six Sigma efficiency.

6.1. Study Limitations

This study assumed that cultural factors can affect the process of implementation of Six Sigma and its ultimate success. It focused on analyzing “soft” factors, and limited the scope of survey to soft factors of culture. The scientific and engineering variables underpinning Six Sigma were not included, and so the structured DMAIC method of Six Sigma is not examined in the survey. Excluding those measurements and data on quality improvement tools and techniques thus reduces the overall explanatory power of these results.

The study utilized the selected dimensions from the Chinese Value Survey. Dimensions selected suit the Six Sigma nature and characteristics, and focused on the implementation process only. Thus, the study only examined a limited number of potential soft factors.

The survey was on respondents from Hong Kong. Strictly speaking, given the substantial regional differences throughout China in market development, the survey results only reflect a partial or regional picture of Six Sigma implementation in China. The Six Sigma methodology has been widely used in the last decade and more in Eastern, Central and Northern China. However, given the broad nature of the Chinese Value Survey, these results may generalize throughout China, but data from other regions of China will be needed to confirm this.

One significant drawback of this research is that data was often retrospective in nature, and thus is subject to recall biases. Longitudinal comparative and case studies may provide a more complete, and thorough understanding of the research topic.

Finally, this study utilized online surveys sent to members of Six Sigma organizations and quality management individuals in Hong Kong, and were restricted by a low response rate. It is unknown whether there was any sort of response bias in the participants who returned the survey. The data collected from the survey is from single respondent, and there was no independent data to verify these self-reports. While factor analysis confirmed the dimensionality and distinctness of the measured variables, there is still the potential for common method variance.

6.2. Future Research

Hempel and Martinsons “examines organizational change initiative in China”, with a goal to “determine how OC initiatives are influenced by non-Western contextual elements” (2009: 460). With the same purpose, the present study uses a quantitative research approach, with a quantitative survey of companies which have introduced Six Sigma, supplemented with qualitative interviews of Six Sigma academics and experts. This line of study can be instrumental for further research. A number of streams of future research are recommended.

Quality associations with or without Western affiliations have been established in China, and assistance from these associations can enable both quantitative methods and mixed methods data collection from field sources. Qualitative methods can also be used. However, its role will be more for confirmatory purpose. To overcome the potential for retrospective bias in the current study, it is suggested that these quality associations be used to identify potential data sources in very early stages of Six Sigma consideration.

In addition, future explorations of the usefulness of the employed culture model (CVS) for the study of organizational change in China are recommended. Most of the predicted relationships were not supported, and it is unknown whether this is due to the relatively small sample size, or if there truly was no relationship. There are two particular areas where future research should focus. One potential area is to examine the way in which clear change objectives aid in Six Sigma implementation. The expectation is that clear objectives prevent the Six Sigma program from getting sidetracked or discarded as not useful. The other potential area for research is to examine in greater detail the surprising finding that an innovation culture appears incompatible with the Six Sigma culture. If so, there are profound implications, with Six Sigma being less appropriate for companies with a strategy focusing on innovation.

Finally, literature identifies other relevant organizational studies models which were not used in this study: (1) Competing Value Framework (CVF), (2) Organizational Culture Index (OCI), and (3) Organizational Citizenship Behavior (OCB). These all have potential application in studying Six Sigma, and can be used to study Chinese organizational change. In addition, while Chinese culture appears to not be either inhibiting, or aiding Six Sigma, other conceptualizations of culture such as the GLOBE project can also be used to study the link between cultural values and Six Sigma implementation.

6.3. Lessons from the Study

This work is built on the shoulders of giants. It is largely an empirical study which investigates cultural influences upon the Six Sigma quality initiative. Its main aim is to confirm knowledge of prior research and experience of practitioner. This adds knowledge to research and gives implications for business.

For quality management, setting objectives for implementation for success is indisputable. The prior literature has already touched on this (Mann & Kehoe, 1995; Pettigrew, 1998; Harry & Schroeder, 2000).

This study on relationship between Chinese culture and Six Sigma implementation is an attempt to fill research gap. The quantitative survey was sent to 70% of the Six Sigma population in Hong Kong. The 116 completed survey responses, though being a low rate, are representative and valid for drawing proper and convincing conclusion for the study.

7. CONCLUSION

The first point to note in this study is that resistance of Six Sigma is seen, but modification by workforce in Hong Kong, the territory of survey, is not a phenomenon. The ultimate completion of the Six Sigma initiative depends upon the setting of clear objectives rather than the details of the Six Sigma implementation. Thus, the management must set clear and definite objectives when introducing Six Sigma in an organization.

As far as Chinese culture in Hong Kong is concerned, three points of interest can be drawn from this survey result. First, the family-bound and socially-based nature of *guanxi* is not reflected in conventional practice in the Six Sigma workplace in Hong Kong. Second, unlike the prediction of previous study reviews, *guanxi* does not have an impact on organizational behavior of companies implementing Six Sigma in Hong Kong. Third, the influence of *guanxi* on firm operation in China is not observed in Six Sigma companies in Hong Kong.

This work ventures to investigate the workability of quality management by Six Sigma in Hong Kong after it has been implemented in its territories for over two decades. Though it is geographically restricted, this study explores into a new stream which academics, seeing its relevancy, may consider related topics of future research in light of its result.

Given that the present researcher is a manager and has been engaging in quality management and education, he will have more opportunities to contribute to research and industrial consultant jobs. This study experience has motivated him to place equal attention to research rigor and practicality. This is what he had been taught in the methodology classes, and what he practiced this in the course of the present study journey. In the role of a quality management consultant, the present researcher must stay alert of the practical needs in the market, and, on the other hand, must also respond properly to the decent call for research scholarship.

REFERENCE LIST

1. Antony, J. and Banuelas, R. (2002). *Key ingredients for the effective implementation of Six Sigma program*. *Measuring Business Excellence*, Vol. 6, No. 4, pp. 20-27.
2. Bond, M. H. et al. (1987). *Chinese values and the search for culture-free dimensions of culture*. *Journal of Cross-Cultural Psychology*, Vol. 18, No. 2, pp. 143-164.
3. Breyfogle III, F. W. (2003). *Implementing Six Sigma: smarter solutions using statistical methods* (2nd ed.). Hoboken, NJ: John Wiley and Sons.
4. Byrne, G. (2003). *Ensuring optimal success with Six Sigma implementations*. *Journal of Organizational Excellence*, Vol. 22, No. 2, pp. 43-50.
5. Chan, C. O. (2006). *The Development and Application of Six Sigma Implementation Model for HK/China Manufacturing Companies*. Unpublished doctor of engineering dissertation, City University of Hong Kong.
6. Cheng, J.L. (2008). *Implementing Six Sigma via TQM improvement: an empirical study in Taiwan*. *The TQM Journal*, Vol. 20, No. 3, pp. 182-195.
7. Coronado, R. B. & Antony, F. (2002). *Critical success factors for the successful implementation of six sigma projects in organizations*. *The TQM Magazine*, Vol. 14, No. 2, pp. 92-99.
8. Detert, J. R., Schroeder, R. G. & Mauriel, J. J. (2000). *A framework for linking culture and improvement initiatives in organization*. *Academy of Management Review*. Vol. 25, No. 4, pp. 850-863.

9. DiBella, A. J. (1996) *Cultural and planned change in an international organization: a multi-level Predicament*. The International Journal of Organizational Analysis, Vol. 4, No. 4, (October), pp. 352-372.
10. Dunning, J. H. and Kim, C. (2007). *The cultural roots of Guanxi: an exploratory study*. The World Economy, Vol 30, pp. 329-341.
11. Earley, P. C. (1989). *Social loafing and collectivism: a comparison of the United States and the People's Republic of China*. Administrative Science Quarterly, Vol. 34, pp.565-581.
12. Fields, D. L. (2002). *Taking the measure of work: a guide to validated scales for organizational research and diagnosis*. Thousand Oaks, CA: Sage.
13. Fotopoulos, C. B. and Psomas, E. L. (2009). *The impact of "soft" and "hard" TQM elements on quality management results*. The International Journal of Quality and Reliability Management. Vol. 26, No. 2, pp. 150-163.
14. Franke, R. H., Hofstede, G. and Bond, M. H. (1991). *Cultural roots of economic performance: a research note*. Strategic Management Journal, Vol. 12, pp. 165-173.
15. Gijo, E. V. and Rao, T. S. (2005). *Six Sigma implementation – hurdles and more hurdles*. Total Quality Management, Vol. 16, No. 6, pp. 721-725.
16. Goetsch, D. L. and Davis, S. (2013). *Quality management for organizational excellence: introduction to total quality* (7th ed.). Boston: Prentice Hall.
17. Gregory, B. T., Harris, S. G., Armenakis, A. A. and Shook, C. L. (2009). *Organizational culture and effectiveness: a study of values, attitudes, and organizational outcomes*. Journal of Business Research, Vol. 62, pp. 673-679.
18. Hall, E. T. (1989). *The Hidden Dimension*. Garden City, NY: Doubleday & Company.
19. Harry, M. & Schroeder, R. (2000). *Six sigma: the breakthrough management strategy Revolutionizing the world's top corporations*. New York, NY: Doubleday.
20. Hempel, P. S. & Martinsons, M. G. (2009). *Developing global organizational change theory using cases from China*. Human Relations, Volume 62(4): 459–499.
21. Hofstede, G. (1980). *Culture's Consequences: International Differences in Work-Related Values*. Newbury Park, CA: Sage.
22. _____. (1986). *Cultural differences in teaching and learning*. International Journal of Intercultural Relations, Vol. 10, No. 3, pp. 301–320.
23. _____. (1993). *Cultural constraints in management theories*. Academy of Management Executive, Vol. 7, No. 1, pp. 81-94.
24. _____. (1994a). *Uncommon sense about organizations*. Thousand Oaks, CA: Sage.
25. _____. (1994b). *The business of international business is culture*. International Business Review, Vol. 3, No. 1, pp. 1-14.
26. Hofstede, G. and Bond, M. H. (1984). *An independent validation using Rokeach's value survey*. Journal of Cross-Cultural Psychology, Vol. 15, No. 4, pp. 417-433.
27. House, R., Javidan, M. and Dorfman, P. (2001). *Project GLOBE: an introduction*. Applied Psychology: an International review, Vol. 50, No. 4, pp. 489-505.
28. Huang, Q., Davison, R. M. and Gu, J. (2008). *Impact of personal and cultural factors on knowledge sharing in China*. Asia Pacific J Manage, Vol. 25, pp. 451-471.
29. Huijser, M. (2006). *The Cultural advantage: a new model for succeeding with global teams*. Boston, Massachusetts: Intercultural Press.
30. Huo, Y. P. and Glinow, M. A. V. (1995). *On transplanting human resource practices to China*. International Journal of Manpower, Vol, 16, No.9, pp. 3-15.
31. Huo, Y. P. and Randall, D. M. (1991). *Exploring subcultural differences in Hofstede's value survey: the case of the Chinese*. Asia Pacific Journal of Management, Vol. 8, No. 2, pp. 159-173.
32. Huo, Z. (2006). *Six-Sigma implementation through competency based perspective (CBP)*. Journal of Change Management, Vol. 6, No. 3, pp. 277-289.
33. Hutchings, K. and Murray, G. (2002). *Working with Guanxi: an assessment of the Implications of globalization on business networking in China*. Creativity and Innovation Management, Vol. 11, No. 3, pp. 184-191.
34. Kubiak, T. M. and Benbow, D. W. (2009). *The certified Six Sigma black belt handbook* (2nd ed.). Milwaukee, WI: American Society for Quality, Quality Press.
35. Kedia, B., and Bhagat, R. (1988). *Cultural constraints on transfer of technology across nations: implications for research in international and comparative management*. Academy of Management Review. Vol. 13, pp. 559-571.
36. Kull, T. J. and Wacker, J. G. (2010). *Quality management effectiveness in Asia: the influence of culture*. Journal of Operations Management, Vol. 28, pp. 223-239.

37. Kwon, J. W. (2012). *Does China have more than one culture?* Asia Pacific Journal of Management, Vol. 29, pp. 79-102.
38. Lee, T. Y., Yeung, K. W. and Wong, W. K. (2011). *Developing a readiness self-assessment model (RSM) for Six Sigma for China enterprises.* International Journal of Quality and Reliability Management, Vol. 28, No. 2, pp. 169-194.
39. Leung, K., Bhagat, R. S., Buchan, N. R., Erez, M. and Gibson, C. B. (2005). *Culture and international business: recent advances and their implications for future research.* Journal of International Business Studies, Vol. 36, pp. 357-378.
40. Lewis, et al. (2006). *Exploring soft versus hard factors for TQM implementation in small and medium-sized enterprises.* International Journal of Productivity and Performance Management, Vol. 55, No. 7, pp. 539-554.
41. Management, Vol. 55, No. 7, pp. 539-554.
42. Lin, L. H. and Ho, Y. L. (2010). *Guanxi and OCB: the Chinese Cases.* Journal of Business Ethics, Vol. 96, pp. 285-298.
43. Luo, Y. and Chen, M. (1997). *Does Guanxi influence firm performance?* Asia Pacific Journal of Management, Vol. 14, pp. 1-16.
44. Mao, Y., Peng, K. Z. and Wong, C. S. (2012). *Indigenous research on Asia: In search of the emic compounds of guanxi.* Asia Pacific Journal of Management, Vol. 29, pp. 1143-1168.
45. Mann, R. and Kehoe D. (1995). *Factors affecting the implementation and success of TQM.* The International Journal of Quality and Reliability. Vol. 12, Iss. 1; pp. 11-23.
46. Martinsons, M. G. and Davison, R. M. (2003). *Cultural issues and IT management: past and present.* IEEE transactions on engineering management, Vol. 50, No. 1, pp. 3-7.
47. Martinsons, M. G., Davison, R. M. and Martinsons, V. (2009). *How culture influences IT-enabled organizational change and information systems.* Communications of the ACM, Vol. 52, No. 4, pp. 118-123.
48. Matthews, B. M. (2000). *The Chinese value survey: an interpretation of value scales and consideration of some preliminary results.* International Education Journal, Vol.1, No. 2, pp. 117-126.
49. McAdam, R. and Evans, A. (2004). *The organisational contextual factors affecting the implementation of Six-Sigma in a high technology mass-manufacturing environment.* Int. J. Six Sigma and Competitive Advantage, Vol. 1, No. 1, pp. 29-43.
50. McAdam, R. and Lafferty, B. (2004). *A multilevel case study critique of Six Sigma: statistical control or strategic change?* International Journal of Operations and Production Management, Vol. 24, No. 5, pp. 530-549.
51. Minkov, M. (2013). *Cross-culture analysis: the science and art of comparing the world's modern societies and their cultures.* Thousand Oaks, California: SAGE.
52. Moosa, K. and Sajid, A. (2010). *Critical analysis of Six Sigma implementation.* Total Quality Management, Vol. 21, No. 7, pp. 745-759.
53. Nahm, A. Y., Vonderembse, M. A. and Koufteros, X. A. (2004). *The impact of organizational Culture on time-based manufacturing and performance.* Decision Sciences, Vol. 35, Num.4, pp. 579-607.
54. Nonhaleerak, P. and Hendry, L. (2006). *Six Sigma: literature review and key future research areas.* International Journal of Six Sigma and Competitive Advantage, Vol. 2, No. 2, pp. 105-161.
55. _____. (2008). *Exploring the Six Sigma phenomenon using multiple case study evidence.* International Journal of Operations and Production Management, Vol. 28, No. 3, pp. 279-303.
56. Pettigrew, A. M. (1998). *“Success and failure in corporate transformation Initiatives”.* In R. D.Galliers and W. R. J. Baets (Ed.). Information technology and organizational transformation. New York: NY, John Wiley and Sons.
57. Pinedo-Cuenca, R., Olalla, P. G. and Setijono, D. (2012). *Linking Six Sigma's critical success/hindering factors and organizational change (development): A framework and a pilot study.* International Journal of Lean Six Sigma, Vol. 3, No. 4, pp.284 – 298.
58. Pisani, M. J., Hayes, R., Kumar, A. and Lepisto, L. (2009). *Is Six Sigma culture bound? A conceptual model and propositions for future inquiry.* Total Quality Management, Vol. 20, No. 10, pp. 1123-1137.
59. Pyzdek, T. and Keller, P. (2010). *The Six Sigma handbook: a complete guide for green belts, black belts and managers at all levels.* New York : McGraw-Hill.
60. Raisinghani, M. S. (2005). *Six Sigma: concepts, tools, and applications.* Industrial Management and Data Systems, Vol. 105, No. 4, pp. 491-505.

61. Rajamanoharan, I. D. and Collier, P. (2006). *Six Sigma implementation, organisational change and the impact on performance measurement systems*. International Journal of Six Sigma and Competitive Advantage, Vol. 2, No. 1, pp. 48-68.
62. Rarick, C. A. (2009). *The historical roots of Chinese cultural values and managerial practices*. Journal of International Business Research, Vol. 8, No. 2, pp. 59-66.
63. Redfern, K. and Crawford, J. (2010). *Regional differences in business ethics in the People's Republic of China: a multi-dimensional approach to the effects of modernisation*. Asia Pacific Journal of Management, Vol. 27, pp. 215-235.
64. Sadagopan, P., Devadasan, S. R. and Goyal, S. K. (2005). *Three Six Sigma transitions and organisational preparedness exercise – today's imperatives for tomorrow's success*. Int. J. Six Sigma and Competitive Advantage, Vol. 1, No. 2, pp. 134-150.
65. Schein, E. H. (1986). *Organizational culture and leadership*. San Francisco, CA: John Wiley and Sons.
66. Szeto, A. Y. T & Tsang, A. H. C. (2005). *Antecedents to successful implementation of Six Sigma*. Int. J. of Six Sigma and Competitive Advantage, Vol. 1, No. 3.
67. Thomson, T. (2003). *Organization Culture and Six Sigma*. In T. Bertel (Ed.). *Rath & Strong's six sigma leadership handbook*. (pp. 141-168) Hoboken, NJ: John Wiley.
68. Tsang, W. K. (1998). *Can guanxi be a source of sustained competitive advantage for doing business in China?* Academy of Management Executive, Vol. 12, No.2 pp. 64-73.
69. Zhang, Y. and Zhang, Z. (2006). *Guanxi and organizational dynamics in China: a link between individual and organizational levels*. Journal of Business Ethics, Vol. 67, pp. 375-392.
70. Zu, X. and Fredendall, L. D. (2009). *Enhancing Six Sigma implementation through human resource management*. The Quality Management Journal, Vol. 16, No. 4, pp. 41-54.
71. Zu, X., Fredendall, L. D., Douglas, T. J. (2008). *The evolving theory of quality management: the role of six sigma*. Journal of Op. Management, Vol. 26, pp. 630-650.
72. Zu, X., Robbins, T. L., Fredendall, L. D. (2010) *Mapping the critical links between organizational culture and TQM/Six Sigma practices*. Int. J. of Production Economics. Vol. 123, pp. 86 – 10